

Designed, Engineered
and Manufactured in ITALY



Evo² Maxx

The Evolution of an International Best Seller

**Speaker
Systems**

Operating Manual



INDEX

| | |
|---------------------------------|--------------------|
| ATTENTION-PRECAUTIONS | 1 |
| INTRODUCTION | 2 |
| GENERAL FEATURES | 3-4-5-6 |
| EVO ² MaxX 2A / 2 | |
| EVO ² MaxX 4A / 4 | |
| EVO ² MaxX 6A / 6 | |
| EVO ² MaxX 9SA | |
| POWER SUPPLY | 7 |
| SAFETY INSTRUCTIONS | 8 |
| ACCESSORIES | 9-10 |
| INSTALLATION MODE | 11-12 |
| CONNECTORS | 13 |
| DIMENSIONS | 14 |
| CONTROLS AND FUNCTIONS | 15-16-17-18 |
| EVO ² MaxX 2A / 2 | |
| EVO ² MaxX 4A / 4 | |
| EVO ² MaxX 6A / 6 | |
| EVO ² MaxX 9SA | |
| PRESET | 19 |
| CONNECTION EXAMPLES | 20-21 |
| TECHNICAL SPECIFICATIONS | 22-23 |



WARNING

RISK OF ELECTRIC SHOCK
DO NOT OPEN



**TO REDUCE THE RISK OF ELECTRIC SHOCK
DO NOT REMOVE COVER (OR BACK)
NO USER SERVICEABLE PARTS INSIDE
REFER SERVICING TO QUALIFIED SERVICE PERSONNEL**

**TO REDUCE THE RISK OF FIRE OR ELECTRIC SHOCK
DO NOT EXPOSE THIS EQUIPMENT TO RAIN OR MOISTURE**



WHERE MARKED, THIS SYMBOL INDICATES A DANGEROUS NON-ISOLATED VOLTAGE INSIDE THE LOUDSPEAKER. SUCH VOLTAGE COULD BE SUFFICIENT TO RESULT IN THE RISK OF ELECTRIC SHOCK.



WHERE MARKED, THIS SYMBOL INDICATES IMPORTANT USAGE AND MAINTENANCE INSTRUCTIONS IN THE ENCLOSED DOCUMENTS. PLEASE REFER TO THE MANUAL.

IMPORTANT SAFETY INSTRUCTIONS

- 1) Read these instructions
- 2) Keep these instructions
- 3) Heed all warnings
- 4) Follow all instructions
- 5) Do not use this apparatus near water
- 6) Clean only with dry cloth
- 7) Do not block any ventilation openings. Install in accordance with the manufacturer's instructions.
- 8) Do not install near any heat sources, such as radiators, heat registers, stoves or other apparatus (including amplifiers) that produce heat
- 9) Do not defeat the safety purpose of the polarized or grounding-type plug. A polarized plug has two blades with one wider than the other. A grounding type plug has two blades and a third grounding prong. The wide blade or the third prong are provided for your safety. If the provided plug does not fit into your outlet, consult an electrician for replacement of the obsolete outlet.
- 10) Protect the power cord from being walked on or pinched particularly at plugs, convenience receptacles, and the point where they exit from the apparatus.
- 11) Only use attachments/accessories specified by the manufacturer.
- 12) Use only with the cart, stand, tripod, bracket, or table specified by the manufacturer or sold with the apparatus. When a cart is used, use caution when moving the cart/apparatus combination to avoid injury from tip-over.
- 13) Unplug this apparatus during lightning storms or when unused for long periods of time.
- 14) Refer all servicing to qualified service personnel. Servicing is required when the apparatus has been damaged in any way, such as power-supply cord or plug is damaged, liquid has been spilled or objects have fallen into the apparatus, the apparatus has been exposed to rain or moisture, does not operate normally, or has been dropped.



THE DEVICE MUST BE CONNECTED TO THE MAINS THROUGH A POWER OUTLET WITH A PROTECTIVE EARTH CONNECTION.

This device features a power outlet ; install the device so that the outlet for the power cord is easily accessible .

PRECAUTIONS

- ° For proper air ventilation please make sure to leave sufficient clearance (min 11 inc.) on all sides of the device.
- ° Please do not cover the ventilation slots with papers, table cloths, curtains, etc. in order not to prevent ventilation of the device.
- ° Please do not place any naked flame source, such as lighted candles, on the device.
- ° Please keep the device away from water springs and splashes and please do not place any objects containing liquids, such as vases, on the device.

INTRODUCTION

Evolving from the FBT EvoMaxX series of loudspeakers, FBT Evo²MaxX speakers feature totally new Digital Sound Processing resulting in improved sound quality and SPL, especially in bass reproduction at high volume.

The sound is more relaxing and natural and the four new DSP presets provide quick dynamic equalization and protection contours for any acoustically challenging venue. Other exciting features are high efficiency and excursion woofers, powerful class D amplifiers with an extremely low noise floor.

Alongside these key performance improvements, FBT has been inspired to develop the Evo²MaxX series by one very important goal- offering the customer more value for money. Evo²MaxX lightweight yet sturdy polypropylene cabinets feature a monitor taper designed to ensure that they perform with excellence no matter whether they are used at front of house for a main sound system, as stage floor monitors or within permanent installations.

Additional options are also available for extending low frequency response in the shape of the 15" subwoofer Evo²MaxX 9SA or the SUBLINE 12SA, 15SA, 18SA, all of which boast birch plywood enclosures.

The Evo²MaxX series consists of four powered and three passive models:

Evo²MaxX 2A/Evo²MaxX 2 (10")

Evo²MaxX 4A/Evo²MaxX 4 (12")

Evo²MaxX 6A/Evo²MaxX 6 (15")

Evo²MaxX 9SA (Subwoofer da 15")



Evo²MaxX 6a
400+100W
Evo²MaxX 6
400W



Evo²MaxX 4a
400+100W
Evo²MaxX 4
300W



Evo²MaxX 2a
400+100W
Evo²MaxX 2
250W



Evo²MaxX 9Sa
600W

Evo² MaxX 2a

Evo² MaxX 2



2-WAY BI-AMPLIFIED BASS REFLEX DESIGN CABINET

- > 10" LF magnet woofer with 2" voice coil, custom made for FBT
- > 1" throat exit B&C HF compression driver
- > Frequency response from 58Hz a 20kHz
- > Biamped: 400W RMS LF, 100W RMS HF, class D power amplifiers with switch mode power supplies
- > Digital Signal Processor with 4 equalization presets
- > Control panel: features balanced XLR/Jack input and XLR link out, volume, preset, HP filter, 3 status led indicators
- > 90°H x 60°V constant directivity horn
- > Sturdy gas-injected polypropylene molded enclosure with one integrated handle and stage floor monitor taper
- > 2xM10 suspension points, 1,38" top-hat speaker stand socket, wall bracket mount flange plate
- > Enclosure suitable for stacking

PASSIVE VERSION

- > Recommended amplifier 250WRMS / 8 Ohm
- > Built-in passive crossover with soft-trip protection for the LF woofer and HF driver
- > Speakon NL4 in and link out connectors

Evo² MaxX 4a

Evo² MaxX 4



2-WAY BI-AMPLIFIED BASS REFLEX DESIGN CABINET

- > 12" LF magnet woofer with 2.5" voice coil, custom made for FBT
- > 1" throat exit B&C HF compression driver
- > Frequency response from 50Hz a 20kHz
- > Biamped: 400W RMS LF, 100W RMS HF, class D power amplifiers with switch mode power supplies
- > Digital Signal Processor with 4 equalization presets
- > Control panel: features balanced XLR/Jack input and XLR link out, volume, preset, HP filter, 3 status led indicators
- > 90°H x 60°V constant directivity horn
- > Sturdy gas-injected polypropylene molded enclosure with integrated handle and stage floor monitor taper
- > 4xM10 suspension points, 1,38" top-hat speaker stand socket, wall bracket mount flange plate
- > Enclosure suitable for stacking

PASSIVE VERSION

- > Recommended amplifier 300WRMS/8 Ohm
- > Built-in passive crossover with soft-trip protection for the LF woofer and HF driver
- > Speakon NL4 in and link out connectors

Evo² MaxX 6a

Evo² MaxX 6



2-WAY BI-AMPLIFIED BASS REFLEX DESIGN CABINET

- > 15" LF magnet woofer with 2.5" voice coil, custom made for FBT
- > 1" throat exit B&C HF compression driver
- > Frequency response from 42Hz a 20kHz
- > Biamped: 400W RMS LF, 100W RMS HF, class D power amplifiers with switch mode power supplies
- > Digital Signal Processor with 4 equalization presets
- > Control panel: features balanced XLR/Jack input and XLR link out, volume, preset, HP filter, 3 status led indicators
- > 90°H x 60°V constant directivity horn
- > Sturdy gas-injected polypropylene molded enclosure with two integrated handles and stage floor monitor taper
- > 4xM10 suspension points, 1,38" top-hat speaker stand socket, wall bracket mount flange plate
- > Enclosure suitable for stacking

PASSIVE VERSION

- > Recommended amplifier 400WRMS / 8 Ohm
- > Built-in passive crossover with soft-trip protection for the LF woofer and HF driver
- > Speakon NL4 in and link out connectors

Evo² MaxX 9Sa



COMPACT BASS-REFLEX DESIGN SUBWOOFER

- > 15" high excursion magnet woofer with 3" voice coil, custom made for FBT
- > Frequency response from 40Hz a 120Hz
- > 600W RMS class D power amplifier with switch mode power supplies
- > Digital Signal Processor with 4 presets, 2 equalization with 2 LPF crossover settings
- > Control panel with balanced Combo XLR/Jack in/outs, XLR HP-Filter outs, volume, preset, Phase, 3 status led indicators
- > Polyethylene cabinet enclosure with internal wooden reinforcements
- > M20 top mount speaker stand socket, two integrated carrying handles
- > Provides additional low frequency reinforcement when used along with 2-way Evo²MaxX speakers

POWER SUPPLY

Before connecting the apparatus to the mains, make sure the supply voltage matches the one indicated on the back of the apparatus.

The power socket also included a fuse box; faulty fuses shall be replaced only with fuses having the same electrical features and value.

220-230V~

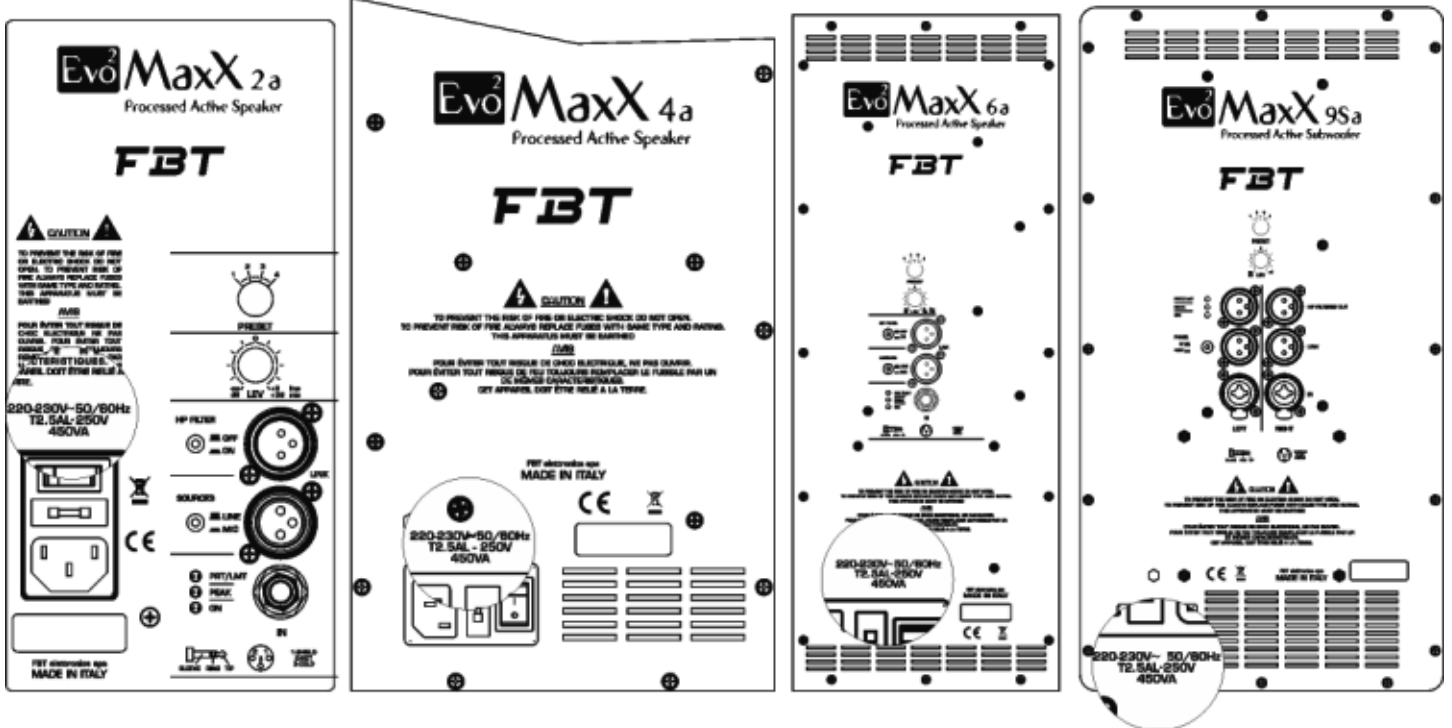

120V~

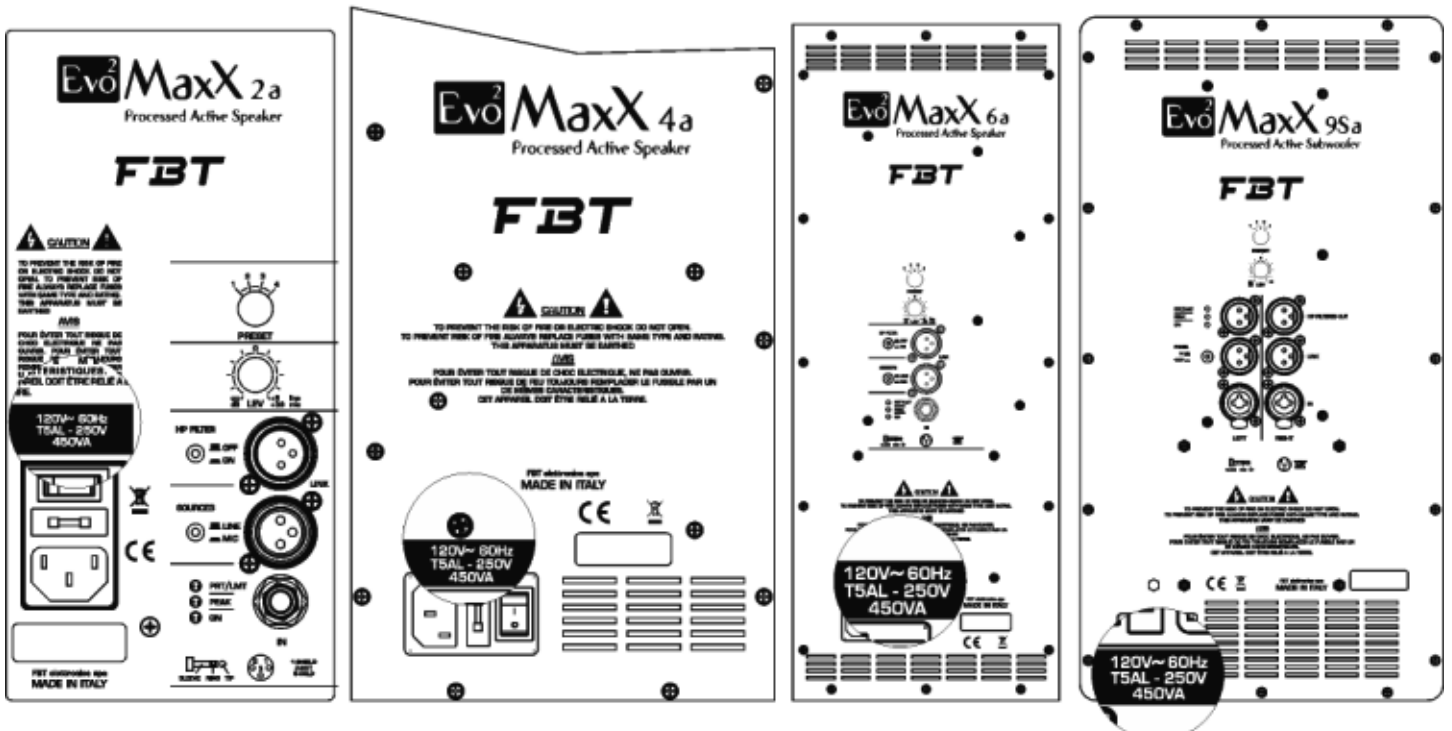

SAFETY INSTRUCTIONS

Evo²MaxX sound speakers must be installed using the flying accessories described in this manual and following the special assembly instructions by qualified staff only, strictly complying with the current regulations and safety standards in force in the country of installation.

FBT flying accessories are manufactured for their exclusive use with **Evo²MaxX** systems and have not been designed for being used with any other speaker or device.

Any possible elements of the ceiling, floor or further supports where **Evo²MaxX** systems are to be installed shall be able to safely bear the load. The flying accessories in use are to be coupled and secured safely to both the sound speaker and the ceiling (or the other support).

When components are fitted to ceilings, floors or beams, always make sure that all couplers and fixing elements are properly sized and have an adequate load capacity.

Besides the main suspension system, all flying speakers in theatres, indoor stadiums or in several other work and/or leisure facilities shall be provided with an additional independent safety system with the adequate load capacity. Only steel cables and chains with certified load capacity can be used as an additional safety device.

WARNING

- > Hang **Evo²MaxX** speakers using only original accessories
- > When choosing the place of installation, the suspension cable and the mounting supports make sure they are able to bear speaker and flying accessories' weight with the proper safety factor
- > As for fixed installations, always schedule and carry out special inspections on a regular basis in order to check all the parts that have to guarantee system safety over time
- > Do not hang the system by the handles: handles have been designed for speaker transport and are not suitable for its suspension
- > Never lean on/hang from the flying speaker

FBT Elettronica SpA accepts no responsibilities for any possible damages or injuries due to the use of supports or structures not strong enough or due to wrong installation

ACCESSORIES

CAUTION

The Evo²MaxX speakers use only with FBT mount for wall installation.

USE WITH OTHER MOUNTS IS CAPABLE OF RESULTING IN INSTABILITY CAUSING POSSIBLE INJURY.

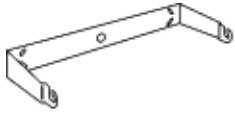

BOX 104

Mount for horizontal wall installation

Evo²MaxX 6/6a

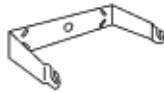

BOX 105

Mount for vertical wall installation

Evo²MaxX 6/6a

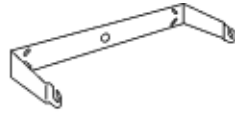

BOX 100

Mount for horizontal wall installation

Evo²MaxX 4/4a

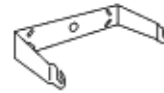

BOX 101

Mount for vertical wall installation

Evo²MaxX 4/4a

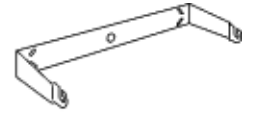

BOX 102

Mount for horizontal wall installation

Evo²MaxX 2/2a

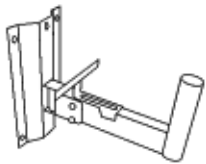

KWM 560

Directional wall mount

Evo²MaxX 4/4a
Evo²MaxX 2/2a

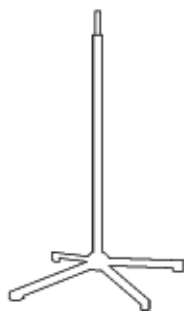

SS2

*Standard speaker floor stand
Max. weight 220lb*

Evo²MaxX

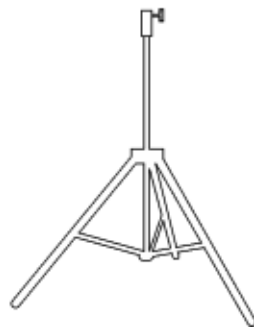

KMS 300

*Adjustable aluminium floor stand, damped safety mechanism
Max. weight 154lb*

Evo²MaxX

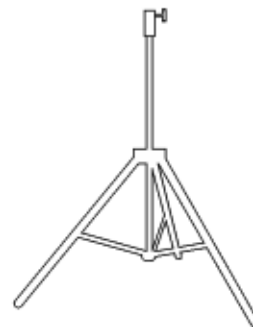

KMS 325

*Adjustable aluminium floor stand Ø1.38" with Ø1" adapter
Max. weight 88lb*

Evo²MaxX



KMS 210

Adjustable for sub-satellite speaker connection with safety locking device Ø1.38"

Evo²MaxX

ACCESSORIES

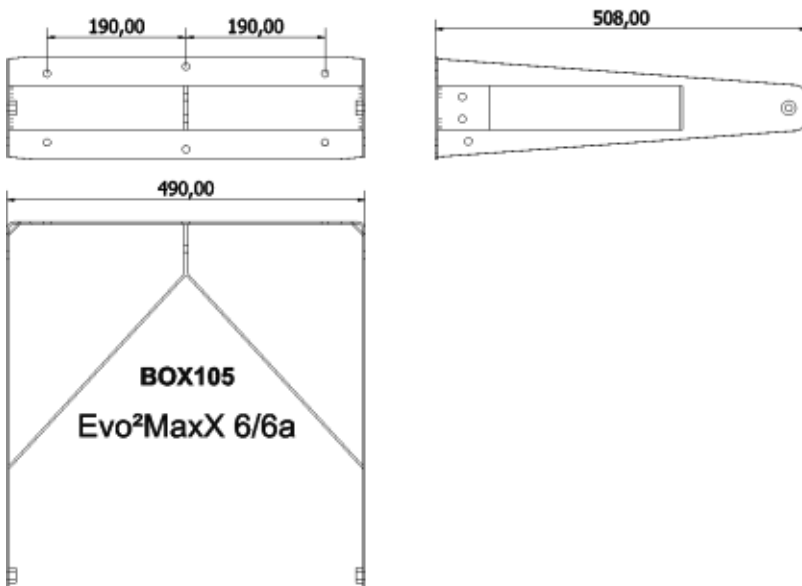
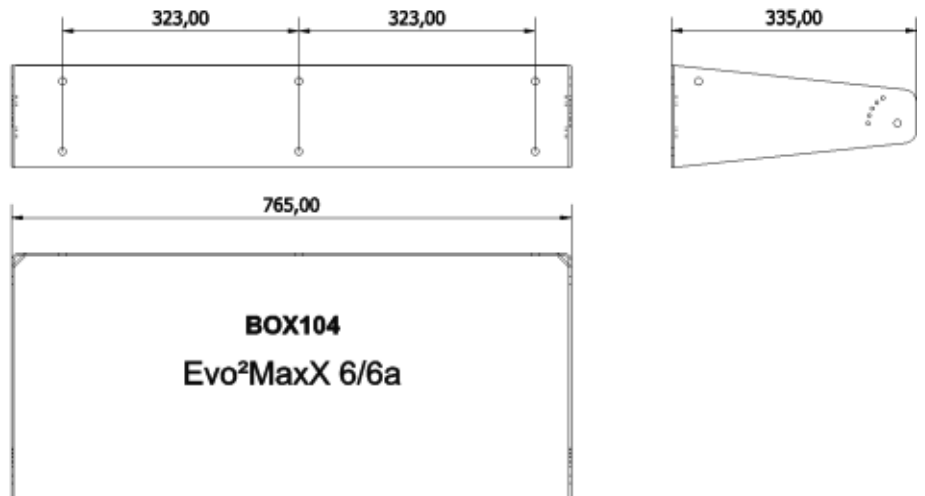
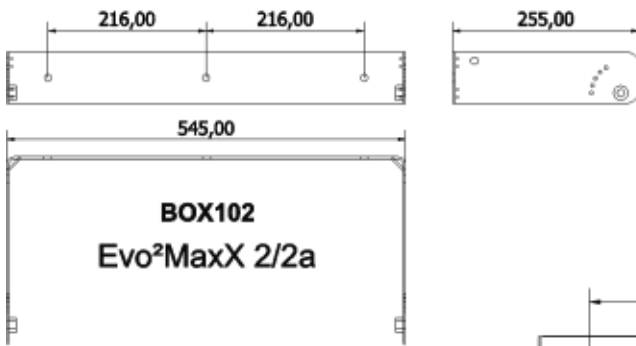
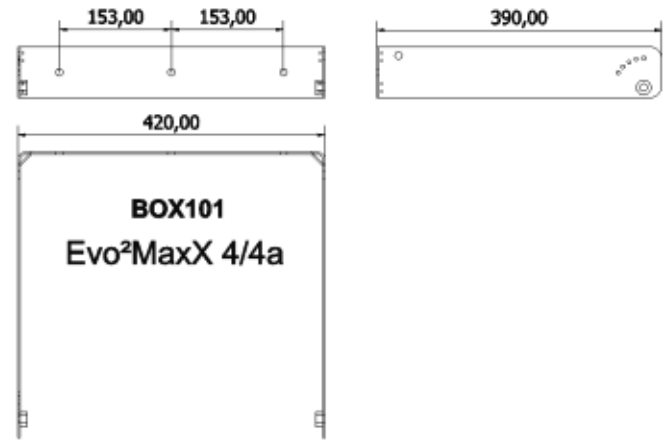
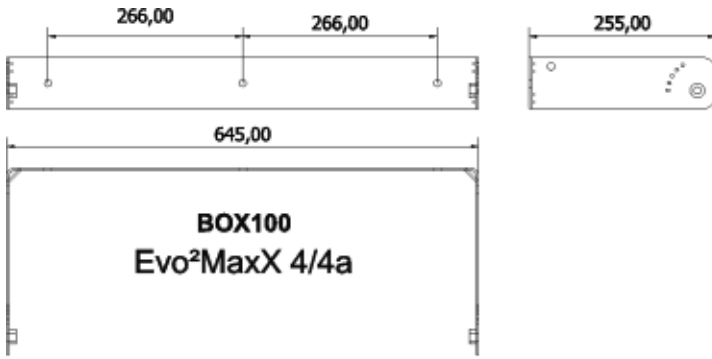

INSTALLATION MODES

Evo²MaxX speakers can be installed as follow:

- a) suspension by wall bracket
- b) installation on tripod stand or coupled with the subwoofer
- c) simple stack installation with the subwoofer on the ground and the relevant satellite on it

Suspension by wall bracket

- 1) Carefully choose speakers place of installation and make sure that the structure can bear box weight
- 2) Remove speaker's four feet
- 3) Secure the bracket to the wall by using screws in all its fixing holes
- 4) Place the speaker between bracket arms and secure it through two M10 threaded inserts
- 5) Point the speaker as desired and lock it through the M6 pin

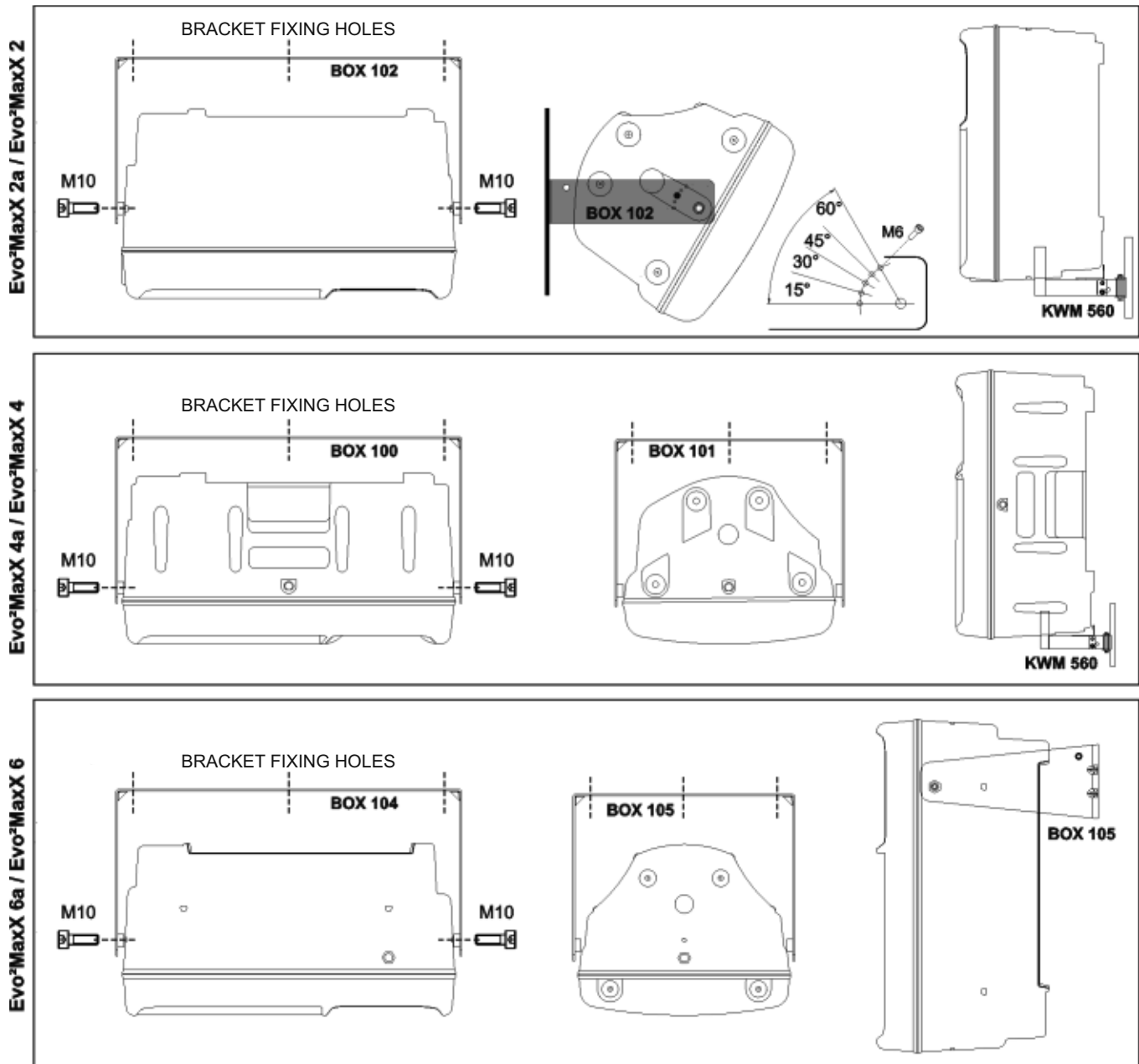

Installation on tripod stand

All Evo²MaxX satellites are designed to be installed on floor stand. Such installation will allow medium-high frequency sources to be better aligned to listener's ear.

With this installation take the following precautions:

- _ Make sure that the stand can bear speaker's weight*
- _ Place the stand on a flat and antislip surface*
- _ Widen stand base as much as possible to increase its stability*

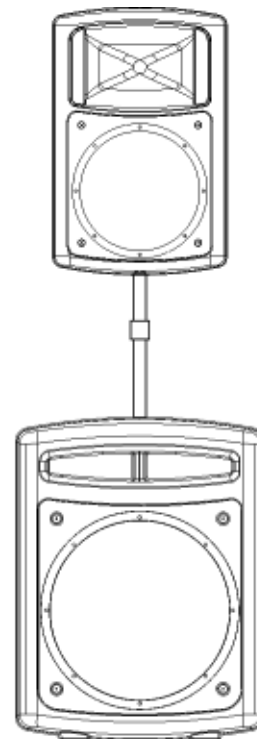
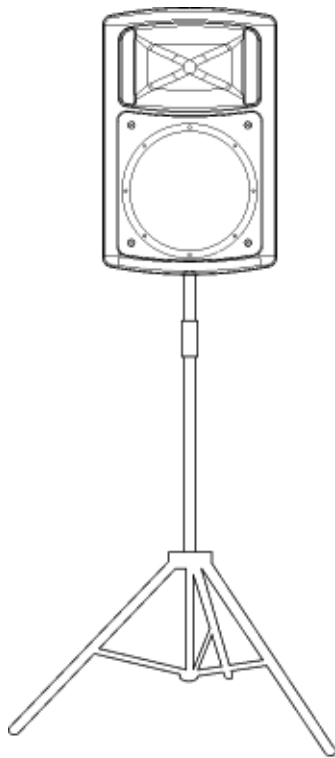

Stack installation

Subwoofer on the ground and the relevant satellite on it

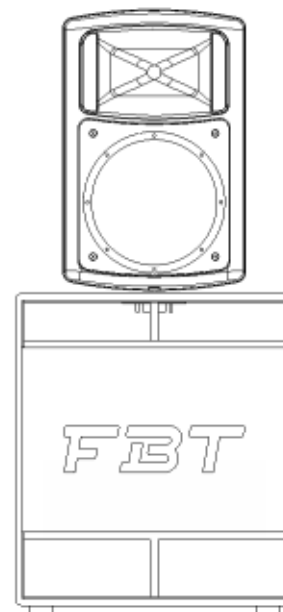

CONNECTORS

The 3-pole XLR connectors are almost always used for conducting mono-balanced signals; the three poles correspond respectively to ground (1), the positive signal (2) and the negative signal (3).

SPEAKON is a connector which is specially adapted for connecting power terminals to loudspeakers; when inserted in an appropriate socket it locks so as to prevent accidental disconnection; moreover, it is equipped with protection against electrical shocks and guarantees the correct polarisation.

The JACKS are typical connectors for the transporting of two separate signals through two channels, left and right, using a single connector and therefore they can be either mono or stereo. Mono jacks (TS) also known as unbalanced jacks, are recognisable from stereo or balanced jacks (TRS) by their composition. The point of the mono jacks is divided into two parts, tip and ground (Tip and Slave) to which the two poles are connected; the stereo or balanced jacks are divided in three parts, as they have a central ring (Ring) which is connected to a second wire, the third (negative) pole.

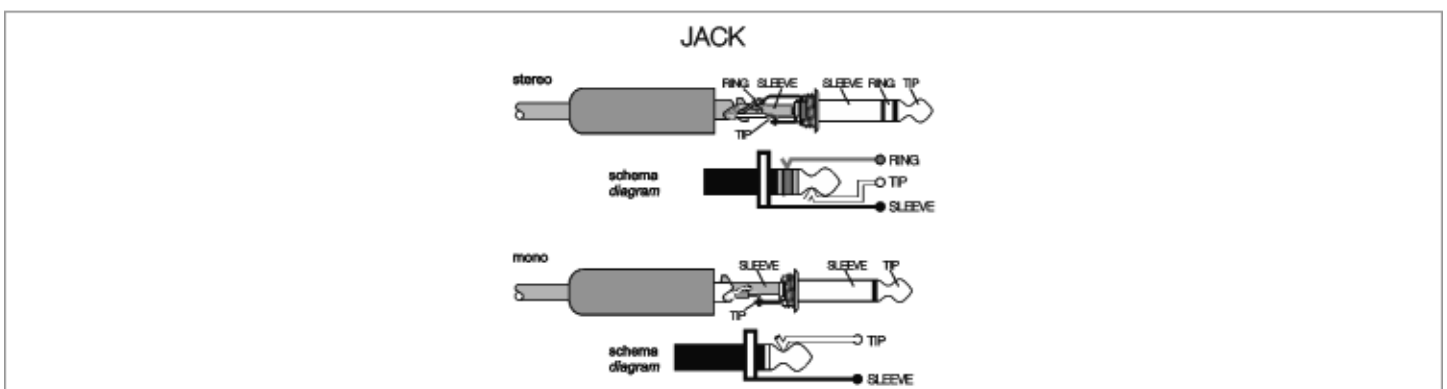
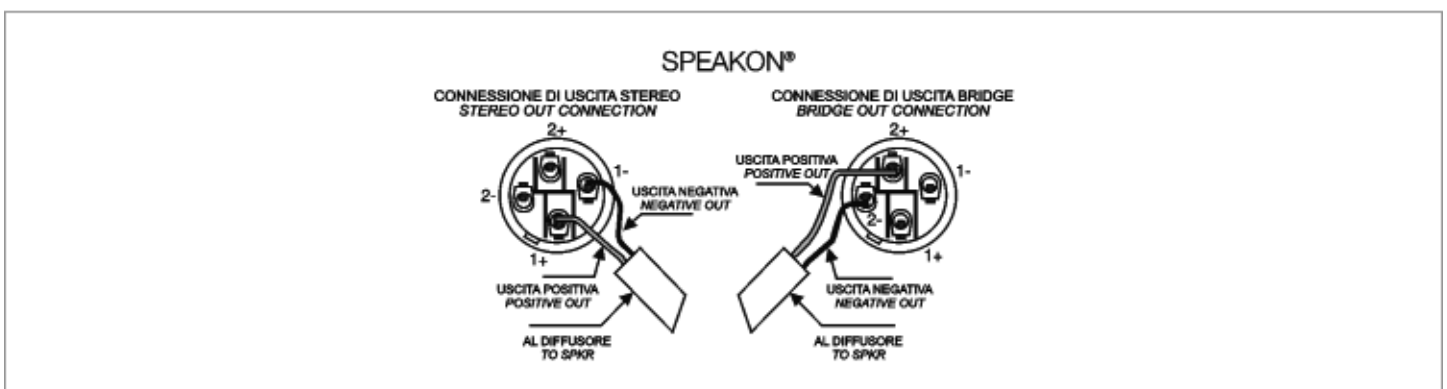
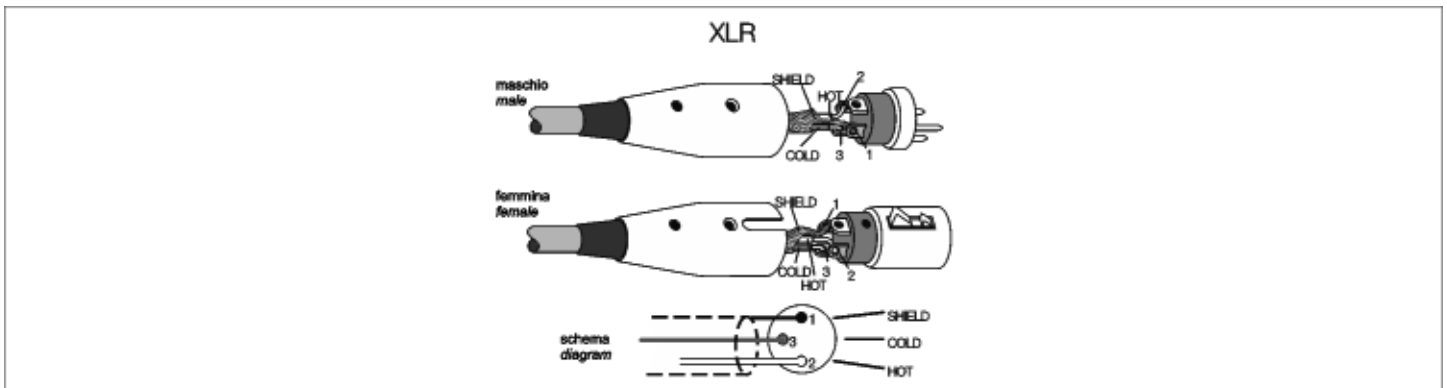

DIMENSIONS

Evo²MaxX_{2a} **Evo²MaxX₂**

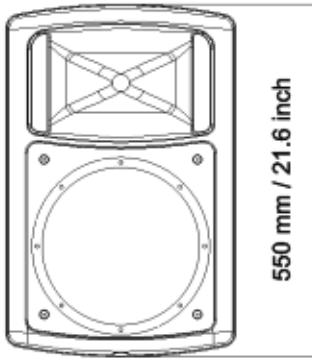

550 mm / 21.6 inch



307 mm / 12.1 inch

352 mm / 13.9 inch

Evo²MaxX₄ **Evo²MaxX_{4a}**

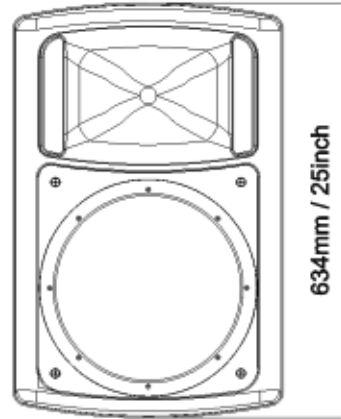

634 mm / 25 inch

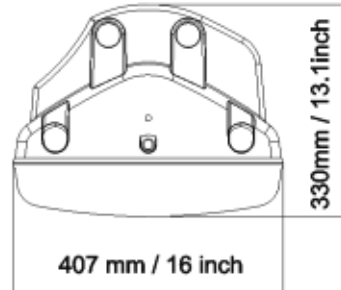

330 mm / 13.1 inch

407 mm / 16 inch

Evo²MaxX_{6a} **Evo²MaxX₆**

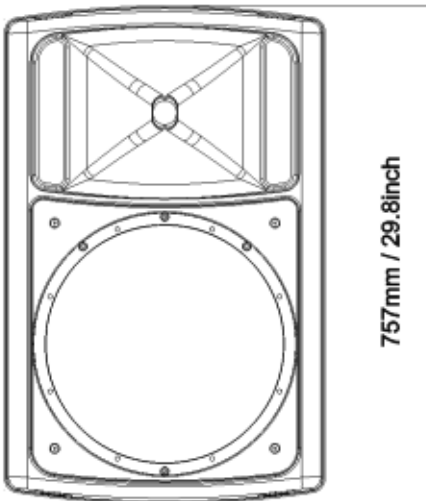

757 mm / 29.8 inch

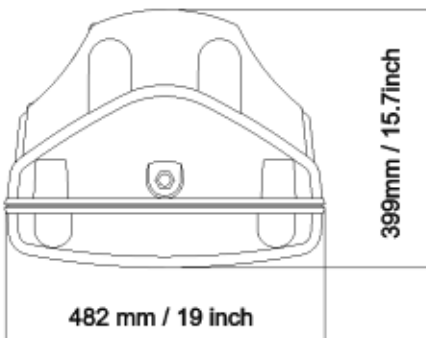

399 mm / 15.7 inch

482 mm / 19 inch

Evo²MaxX_{9Sa}

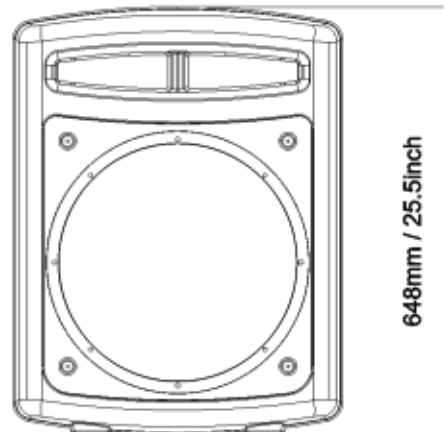

648 mm / 25.5 inch

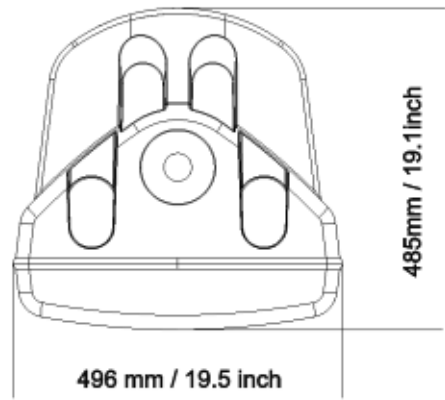

485 mm / 19.1 inch

496 mm / 19.5 inch

PRESET select 4 preset each of whom corresponds to a different equalization according to user's personal preferences and to the acoustics of the listening area (see PRESET section).

LEV adjusts the signal general level.

HP FILTER this switch activates the «low cut» filter which lets only the frequencies above the cut-off frequency pass at the output (TO BE ACTIVATED IN THE CONFIGURATION WITH THE SUBWOOFER).

SOURCES position the switch to «MIC» if a microphone is connected; position to «LINE» when connecting a high level signal source.

IN - LINK balanced input/output sockets; «IN» allows to connect a pre-amplified signal such as that coming, for instance, from mixer output; «LINK» allows to connect multiple speakers to the same signal.

PRT/LIMIT if this led lights up there is a system malfunction due to an internal amplifier failure or to the intervention of current limiting circuits against thermal overload.

PEAK when this led lights up it indicates that the signal is reaching saturation.

ON indicates that the system is on.

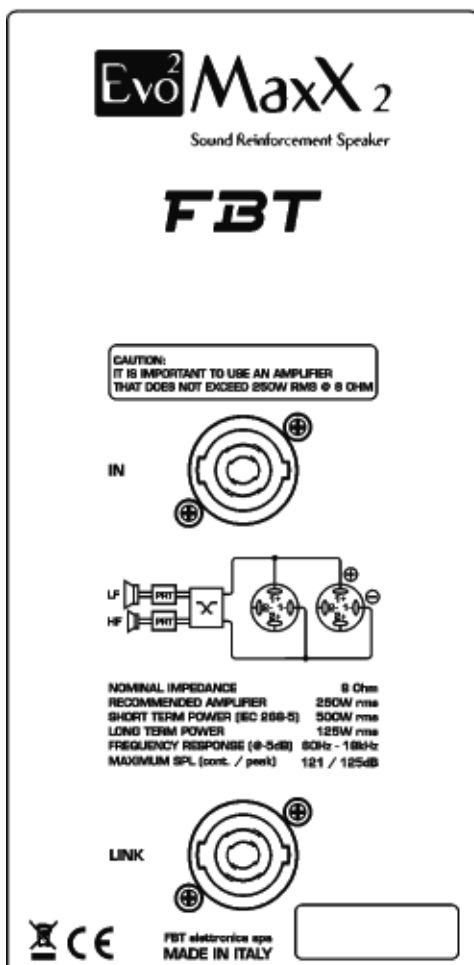
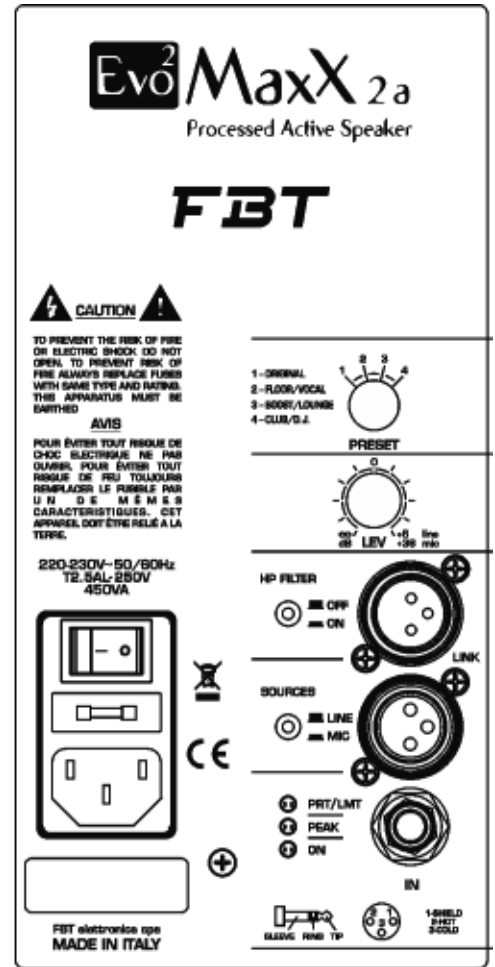

When connecting any Line level device (mixer, electronic keyboard, etc.) to the powered Evo²MaxX speakers use a shielded audio cable preferably a 1/4" TRS balanced or a balanced XLR type cable. NEVER USE A SPEAKER CABLE with any powered speaker to make connections. Failure to do so will result in hum, buzz, signal loss and can damage your Evo²MaxX speakers, and other equipment connected.

Avoid sending a line signal (from a mixer, an electronic keyboard, a bass or guitar amplifier, etc.) with the MIC/LINE switch in the MIC position. Doing so will result in damage to, or the complete failure of the loudspeakers: woofer, high frequency driver as well as the Evo²MaxX internal power amplifiers. The MIC/LINE switch should only be placed in the MIC position when connecting a low impedance dynamic microphone directly into the powered Evo²MaxX speakers.

Speakon connectors are connected in parallel mode. One connector can be used to connect the box to the output of a power amplifier, the other to connect to a second box.

Loudspeaker cables shall have the adequate diameter, depending on the overall length of the connection. The resistance introduced by an inadequate wiring towards the loudspeakers would reduce both the power output and the damping factor of the loudspeaker.

PRESET_ select 4 preset each of whom corresponds to a different equalization according to user's personal preferences and to the acoustics of the listening area (see PRESET section).

LEV_ adjusts the signal general level.

HP FILTER_ this switch activates the «low cut» filter which lets only the frequencies above the cut-off frequency pass at the output (TO BE ACTIVATED IN THE CONFIGURATION WITH THE SUBWOOFER).

SOURCES_ position the switch to «MIC» if a microphone is connected; position to «LINE» when connecting a high level signal source.

IN - LINK_ balanced input/output sockets; «IN» allows to connect a pre-amplified signal such as that coming, for instance, from mixer output; «LINK» allows to connect multiple speakers to the same signal.

PRT/LIMIT_ if this led lights up there is a system malfunction due to an internal amplifier failure or to the intervention of current limiting circuits against thermal overload.

PEAK_ when this led lights up it indicates that the signal is reaching saturation.

ON_ indicates that the system is on.

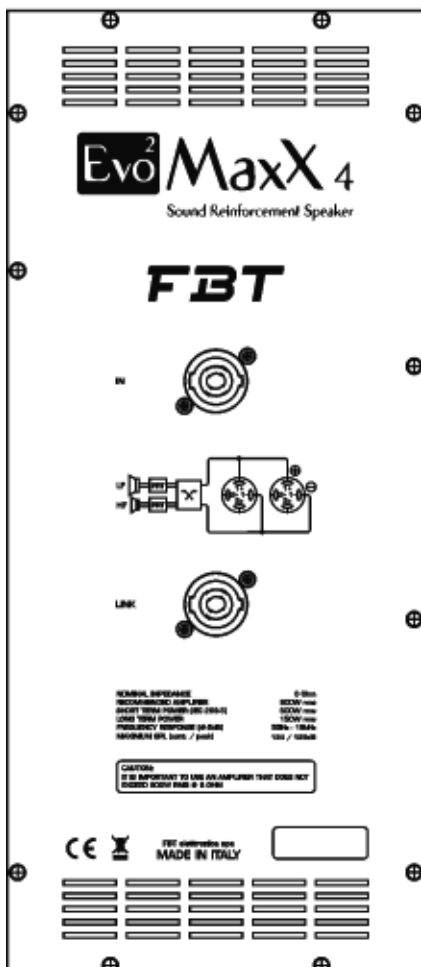
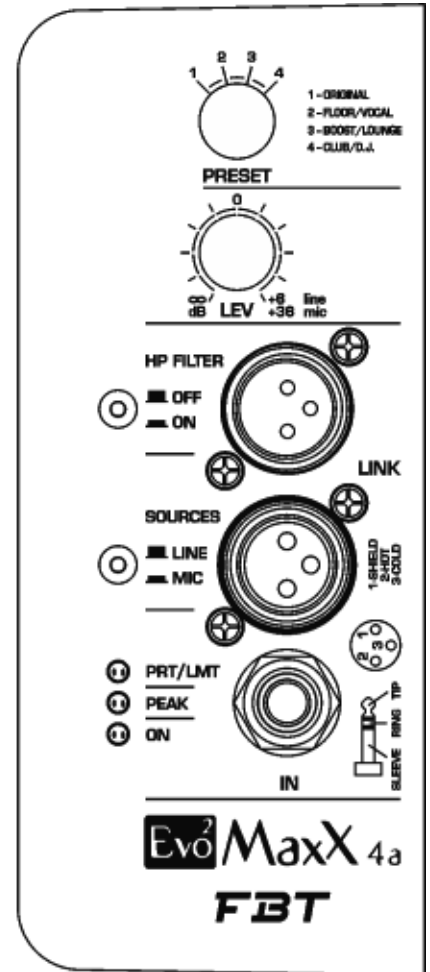

When connecting any Line level device (mixer, electronic keyboard, etc.) to the powered Evo²MaxX speakers use a shielded audio cable preferably a 1/4" TRS balanced or a balanced XLR type cable. NEVER USE A SPEAKER CABLE with any powered speaker to make connections. Failure to do so will result in hum, buzz, signal loss and can damage your Evo²MaxX speakers, and other equipment connected.

Avoid sending a line signal (from a mixer, an electronic keyboard, a bass or guitar amplifier, etc.) with the MIC/LINE switch in the MIC position. Doing so will result in damage to, or the complete failure of the loudspeakers: woofer, high frequency driver as well as the Evo²MaxX internal power amplifiers. The MIC/LINE switch should only be placed in the MIC position when connecting a low impedance dynamic microphone directly into the powered Evo²MaxX speakers.

Speakon connectors are connected in parallel mode. One connector can be used to connect the box to the output of a power amplifier, the other to connect to a second box.

Loudspeaker cables shall have the adequate diameter, depending on the overall length of the connection. The resistance introduced by an inadequate wiring towards the loudspeakers would reduce both the power output and the damping factor of the loudspeaker.

PRESET_ select 4 preset each of whom corresponds to a different equalization according to user's personal preferences and to the acoustics of the listening area (see PRESET section).

LEV_ adjusts the signal general level.

HP FILTER_ this switch activates the «low cut» filter which lets only the frequencies above the cut-off frequency pass at the output (TO BE ACTIVATED IN THE CONFIGURATION WITH THE SUBWOOFER).

SOURCES_ position the switch to «MIC» if a microphone is connected; position to «LINE» when connecting a high level signal source.

IN - LINK_ balanced input/output sockets; «IN» allows to connect a pre-amplified signal such as that coming, for instance, from mixer output; «LINK» allows to connect multiple speakers to the same signal.

PRT/LIMIT_ if this led lights up there is a system malfunction due to an internal amplifier failure or to the intervention of current limiting circuits against thermal overload.

PEAK_ when this led lights up it indicates that the signal is reaching saturation.

ON_ indicates that the system is on.

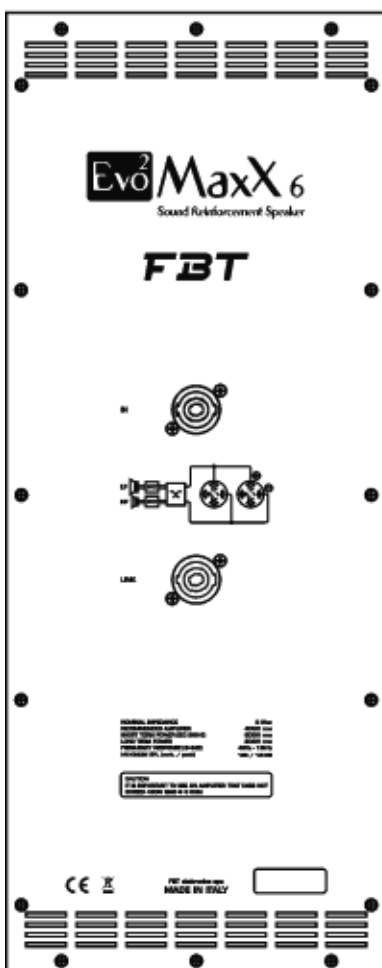
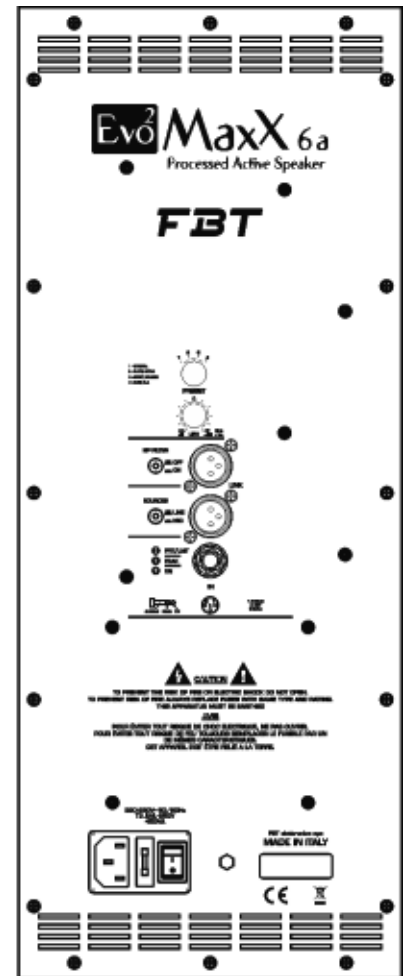

When connecting any Line level device (mixer, electronic keyboard, etc.) to the powered Evo²MaxX speakers use a shielded audio cable preferably a 1/4" TRS balanced or a balanced XLR type cable. NEVER USE A SPEAKER CABLE with any powered speaker to make connections. Failure to do so will result in hum, buzz, signal loss and can damage your Evo²MaxX speakers, and other equipment connected.

Avoid sending a line signal (from a mixer, an electronic keyboard, a bass or guitar amplifier, etc.) with the MIC/LINE switch in the MIC position. Doing so will result in damage to, or the complete failure of the loudspeakers: woofer, high frequency driver as well as the Evo²MaxX internal power amplifiers. The MIC/LINE switch should only be placed in the MIC position when connecting a low impedance dynamic microphone directly into the powered Evo²MaxX speakers.

Speakon connectors are connected in parallel mode. One connector can be used to connect the box to the output of a power amplifier, the other to connect to a second box.

Loudspeaker cables shall have the adequate diameter, depending on the overall length of the connection. The resistance introduced by an inadequate wiring towards the loudspeakers would reduce both the power output and the damping factor of the loudspeaker.

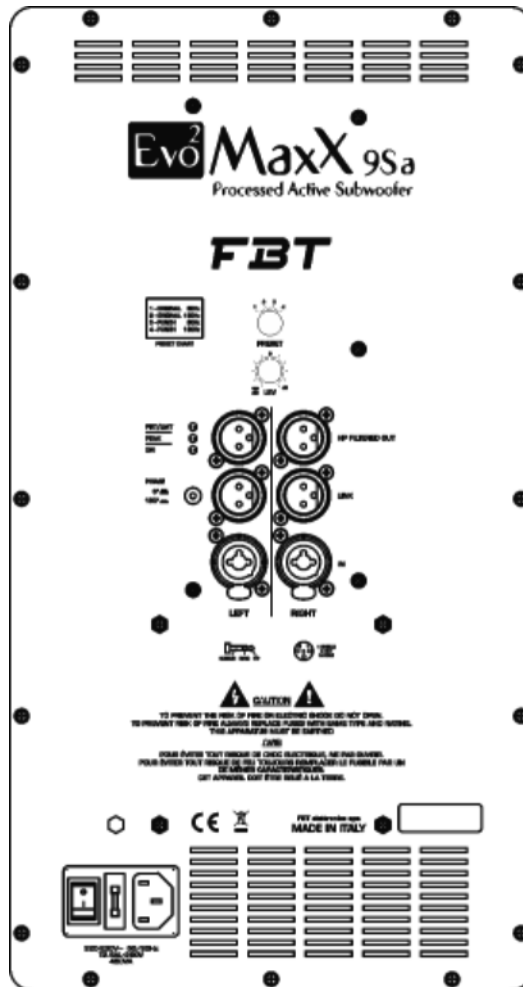

PRESET_ select 4 preset each of whom corresponds to a specific speaker configuration according to user's personal preferences and to the acoustics of the listening area (see PRESET section).

LEV_ adjusts the signal general level.

HP FILTERED OUT_ output for taking the filtered signal and sending it to an amplified satellite without HP filter (N.B. FOR THE CONNECTION OF Evo²MaxX SATELLITES USE THE OUTPUT «LINK»); this avoids having the two connected speakers operate within the same frequency interval, and thus obtains a complex response without interference.

PRT/LIMIT_ if this led lights up there is a system malfunction due to an internal amplifier failure or to the intervention of current limiting circuits against thermal overload.

PEAK_ when this led lights up it indicates that the signal is reaching saturation.

ON_ indicates that the system is on.

PHASE_ the Phase control allows to optimize phase alignment, i.e. to obtain a uniform frequency response in the crossover area between the sub and the satellite. When it is set at «0°» the sound emission is in phase with the input signal; when it is set at «180°» the sound emission is in counterphase with the input signal; thanks to this control subwoofer adjustment will be even more flexible with a consequent performance optimization.

IN - LINK_ balanced input/output sockets; «IN» allows to connect a pre-amplified signal such as that coming, for instance, from mixer output; «LINK» allows to connect multiple speakers to the same signal.

PRESET

Instead of rotary EQ controls, FBT's new Digital Signal Processor with 4 factory equalization presets provides simple and efficient EQ adjustment. Hundreds of hours of testing in the anechoic chamber in our factory went into the development of these presets to optimize the Evo²MaxX speakers for use for numerous applications. Selection is made through the "PRESET" switch.

| | |
|-------------------------------|--|
| Evo²MaxX 2a | 1 - ORIGINAL 2 - FLOOR/VOCAL 3 - BOOST/LOUNGE 4 - CLUB/D.J. |
| Evo²MaxX 4a | |
| Evo²MaxX 6a | |

- ORIGINAL: corresponding FBT benchmark sound for use in general applications.
- FLOOR/VOCAL: the Evo²MaxX immediately becomes an ideal stage monitor. Also suited for high clarity and intelligibility vocal reproduction.
- BOOST/LOUNGE: providing loudness contour with increased bass response for a relaxing and very enjoyable listening, especially at low and medium volume.
- CLUB/D.J.: providing all the punch and full-bodied response required by DJ users, suitable for high volume "disco" and "party" applications.

| | |
|--------------------------------|--|
| Evo²MaxX 9Sa | 1 - ORIGINAL 80Hz 2 - ORIGINAL 120Hz 3 - PUNCH 80Hz 4 - PUNCH 120Hz |
| | |
| | |
| | |

- **ORIGINAL**: corresponds to the typical FBT sound; it is the default general purpose preset and is thus fit for the majority of applications.
- **PUNCH**: the sound of the sub becomes drier, reduced low frequency extension but more energy. Suitable for rock music and high SPL applications.

Two presets feature 2 different cut-off frequencies (80, 120Hz) enabling sub configuration with any other speaker.

CONNECTION EXAMPLES

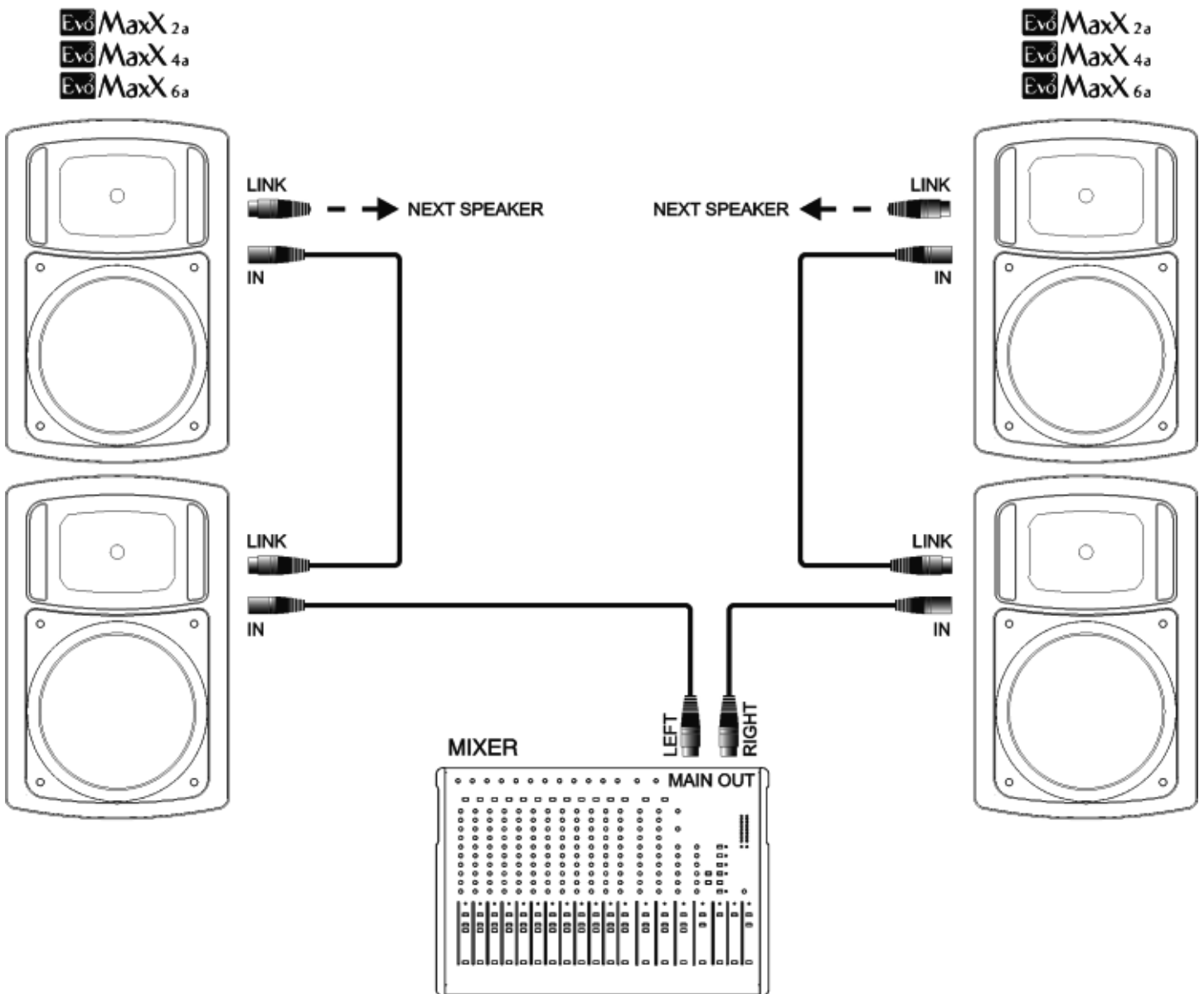
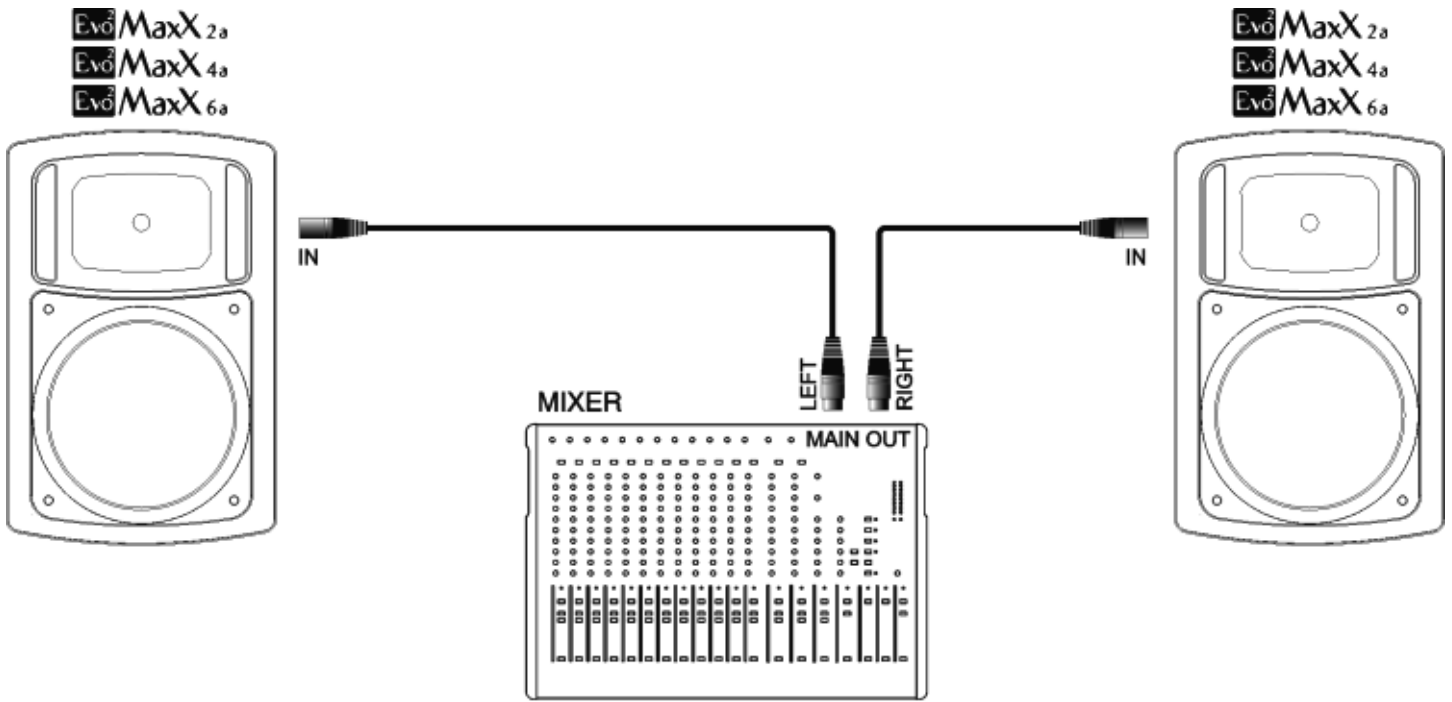

CONNECTION EXAMPLES

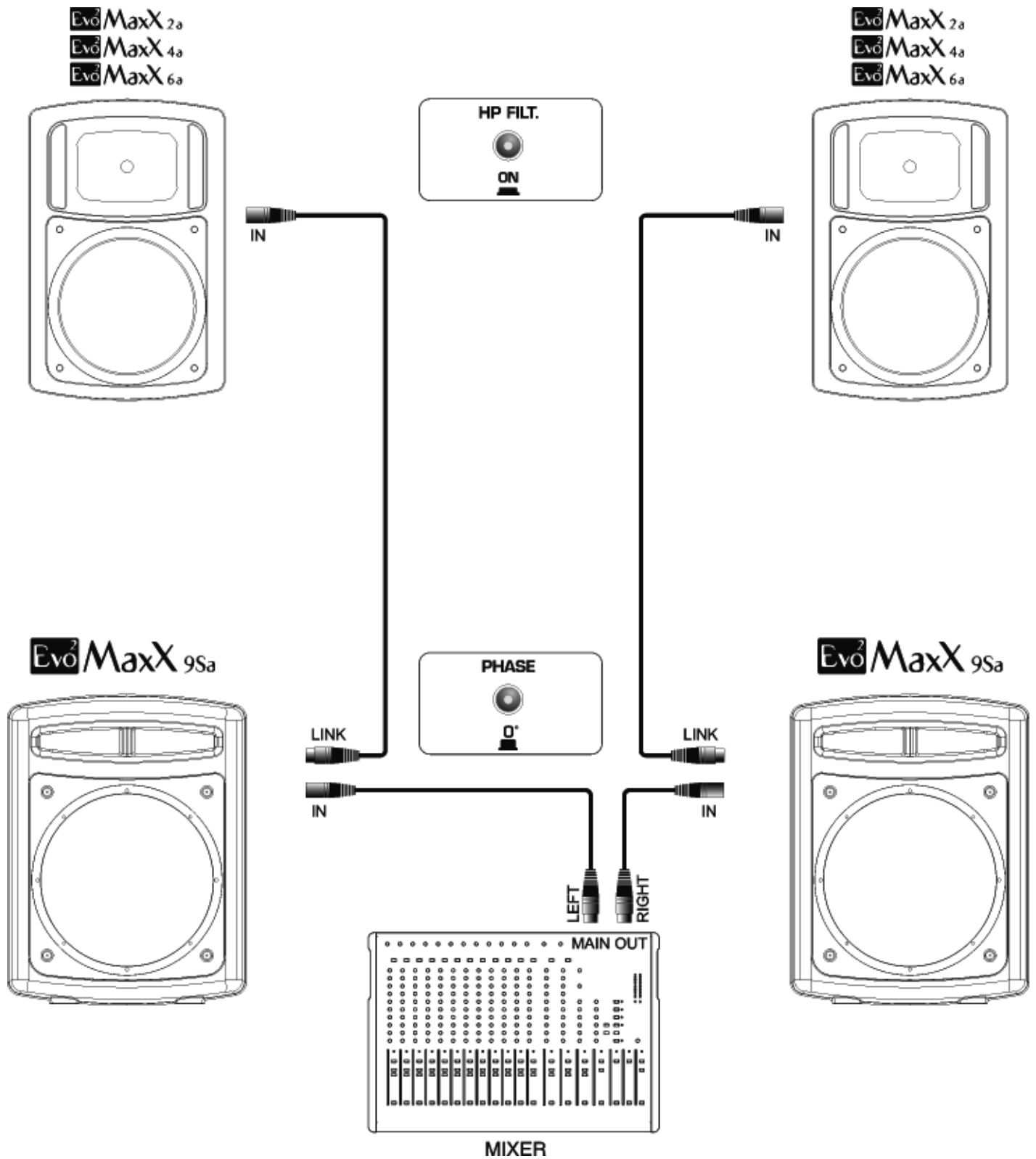

For sub/satellite configurations set sub PHASE switch to "0°" and satellite HP FILTER switch to "ON".

TECHNICAL SPECIFICATIONS

| | | Evo²MaxX 6A | Evo²MaxX 4A | Evo²MaxX 2A | Evo²MaxX 9SA |
|-------------------------------------|------|-------------------------------|-------------------------------|-------------------------------|--------------------------------|
| Configuration | way | 2 | 2 | 2 | 1 |
| Built-in Amplifier cont. RMS LF/HF | W | 350/80 | 350/80 | 350/80 | 400 |
| Built-in Amplifier max. RMS LF/HF | W | 400/100 | 400/100 | 400/100 | 600 |
| Built-in Amplifier max. peak. LF/HF | W | 800/200 | 800/200 | 800/200 | 1200 |
| Frequency Response | -6dB | 42Hz-20kHz | 50Hz-20kHz | 58Hz-20kHz | 40Hz-120Hz |
| Low Frequency Woofer | inch | 1x15 / coil 2.5 | 1x12 / coil 2.5 | 1x10 / coil 2 | 1x15 / coil 3 |
| High Frequency Driver | inch | 1x1 / coil 1.7 | 1x1 / coil 1.4 | 1x1 / coil 1.4 | ----- |
| Max. SPL cont/peak | dB | 126 / 131 | 124 / 130 | 122.5 / 128 | 128 / 132 half-space |
| Dispersion | HxV | 90°x60° | 90°x60° | 90°x60° | omnidirectional |
| Input Impedance | kOhm | 22 | 22 | 22 | 22 |
| Crossover Frequency | kHz | 1.6 | 1.6 | 1.8 | preset dependant |
| AC Power Requirement | VA | 450 | 450 | 450 | 450 |
| Input Connectors | | XLR with loop | XLR with loop | XLR with loop | XLR with loop HP out |
| Power Cord | ft | 5 | 5 | 5 | 5 |
| Net Dimensions (WxHxD) | inch | 19x29.8x15.7 | 16x25x13 | 13.9x21.6x12.1 | 19.5x25.5x19.1 |
| Net Weight | lb | 53.8 | 34.4 | 26.5 | 48.4 |
| Transport Dimensions (WxHxD) | inch | 23.4x34.6x20.3 | 20.1x29.1x16.1 | 17.1x24.8x15.5 | 23.4x29.9x22.6 |
| Transport Weight | lb | 62.6 | 40 | 31.5 | 57.4 |
| | | Evo²MaxX 6 | Evo²MaxX 4 | Evo²MaxX 2 | |
| Configuration | way | 2 | 2 | 2 | |
| Recommended Amplifier (rms) | W | 400 | 300 | 250 | |
| Long Term Power | W | 200 | 150 | 125 | |
| Short Term Power (IEC 268-5) | W | 800 | 600 | 500 | |
| Nominal Impedance | Ohm | 8 | 8 | 8 | |
| Frequency Response | -6dB | 48Hz-18kHz | 55Hz-18kHz | 60Hz-18kHz | |
| Low Frequency Woofer | inch | 1x15 / coil 2.5 | 1x12 / coil 2.5 | 1x10 / coil 2 | |
| High Frequency Driver | inch | 1x1 / coil 1.7 | 1x1 / coil 1.4 | 1x1 / coil 1.4 | |
| Sensitivity (@1W/1mt) | dB | 99 | 98 | 97 | |
| Max SPL cont/peak | dB | 126 / 130 | 124 / 128 | 121 / 125 | |
| Dispersion | HxV | 90°x60° | 90°x60° | 90°x60° | |
| Crossover Frequency | kHz | 1.6 | 1.6 | 1.8 | |
| Recommended HP Filter | | 40Hz-24dB oct | 45Hz-24dB oct | 50Hz-24dB oct | |
| Input Connectors | | 2 x speakon NL4 | 2 x speakon NL4 | 2 x speakon NL4 | |
| Net Dimensions (WxHxD) | inch | 19x29.8x15.7 | 16x25x13 | 13.9x21.6x12.1 | |
| Net Weight | lb | 54.6 | 35 | 28 | |
| Transport Dimensions (WxHxD) | inch | 23.4x34.6x20.3 | 20.1x29.1x16.1 | 17.1x24.8x15.5 | |
| Transport Weight | lb | 62 | 40.3 | 32 | |

AES LONG TERM APPLICABLE POWER denotes the thermal power that can be dissipated by the loudspeaker or by the individual drivers when operated in BI-AMP mode. This value is measured in accordance with the AES standard, which involves a 2 hour test with pink noise signal, crest factor of 2. Power is determined by the square of the RMS voltage divided by the minimum impedance of the loudspeaker or the individual driver.

IEC268-5 SHORT TERM APPLICABLE POWER corresponds to the power that the loudspeaker can withstand for a very short time interval. This value corresponds to 4 times the AES power value and it is calculated on the basis of the maximum peak voltage that the recommended amplifier can supply to the loudspeaker. Capacities in terms of SPL in transient components of music signals, effectively correspond to the short term applicable power value; therefore, the max. SPL value specified in the technical specifications table is calculated on the basis of this power value

WARNING: the power value that effectively corresponds to the thermal capacity of the loudspeaker to dissipate electrical energy over the long term is represented by the AES value. All other values refer to the "transient capacity" of the loudspeaker to accept power inputs, correlated with the nature of the audio signal.

Although the power of **THE RECOMMENDED AMPLIFIER** is not measured, it is equivalent to double the AES power value and it takes account of the dynamic capacities of the speakers to withstand short duration power peaks. The value supplied corresponds to the RMS power required of the amplifier in order to supply the test signal (pink noise with crest factor 2) utilised to measure AES power.

An amplifier of this power, if used with music signals with crest factor greater than or equal to 6dB, makes it possible to get the best performance out of the speaker, delivering a long term power output that is no higher than the AES power of the loudspeaker.

On the contrary, when using highly compressed music signals or if the amplifier volume is increased to the point of intensive clipping, then the effective long term power tends to reach or even exceed the RMS output of the amplifier, resulting in irreversible damage to the speakers.

With signals of this type it is always advisable to use an amplifier whose RMS output is identical to the speaker AES power, while taking care to ensure that the signal supplied is such that the amplifier is not caused to function in clipping mode too frequently.

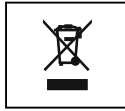

WARNING: where affixed on the equipment or package, the barred waste bin sign indicates that the product must be separated from other waste at the end of its working life for disposal. At the end of use, the user must deliver the product to a suitable recycling centre or return it to the dealer when purchasing a new product. Adequate disposal of the decommissioned equipment for recycling, treatment and environmentally compatible disposal contributes in preventing potentially negative effects on the environment and health and promotes the reuse and/or recycling of equipment materials. Abusive product disposal by the user is punishable by law with administrative sanctions.

CODE 38076#052013

All informations included in this operating manual have been scrupulously controlled; however FBT is not responsible for eventual mistakes. FBT Elettronica SpA has the right to amend products and specifications without notice.